

Systems Development SDD-5000 Automatic Video Tracker

Features

- Track Modes
 - Centroid
 - Correlation
- Multi-Modal Target Contrast Segmentation
- Adaptive Gates
- Intelligent Coast Mode
- Two Video Outputs with Separate Graphic Memories, Each of Which Can Provide Symbology and Text Outputs
- Host Computer Interface Options
 - High Speed Parallel
 - Serial
 - Mil-STD-1553B Communication Interface
- Built-In-Test
- Advanced Servo Systems
- Field Configurable for Various Scenarios
- Visible or Infrared Imagery
- VMEbus Interface Compatible
- Commercial to Full Mil-Spec Qualified

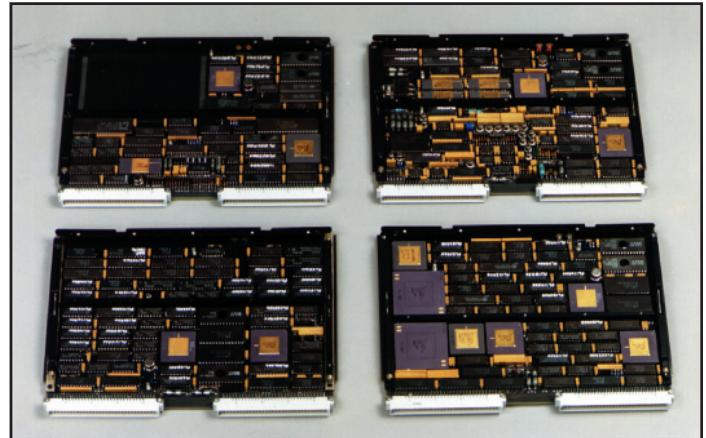

Description and Operation

The SDD-5000 is a non-developmental video tracking system, designed to provide high performance automatic tracking for many different scenarios. The SDD-5000 was designed with state-of-the-art components including a 32-bit CPU, CMOS Digital Signal Processors, and high speed CMOS logic. The hardware design allows for algorithm development in a high-level language such that the SDD-5000 can be configured for many applications.

The SDD-5000's modular VMEbus design features centroid, correlation and intelligent coast modes for visible or infrared target tracking. Its open architecture will allow for integration of additional modules for unique applications or future upgrades. Commercial and ruggedized 19-inch rack, as well as military ATR chassis configurations, are available.

The Intelligent I/O module can be programmed to implement the platform's servo algorithm for direct drive of the platform.

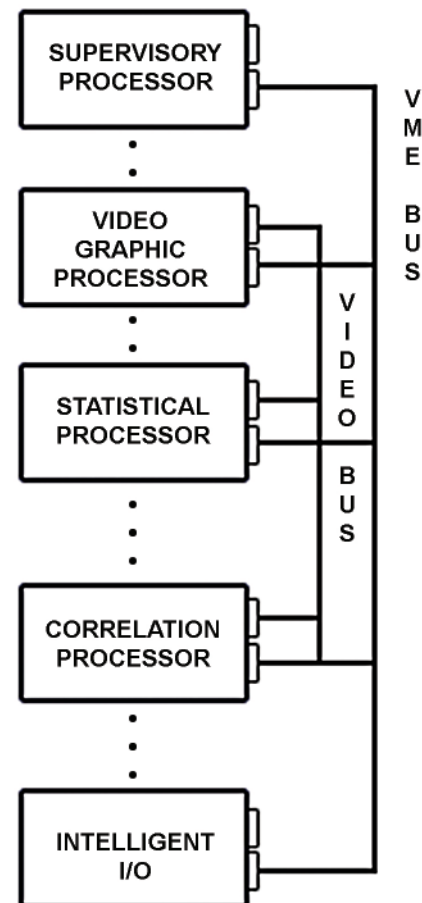

Specifications

VIDEO INPUT AND OUTPUT

Video Input

RS-170A or CCIR B/W or color video with 1.1V to 1 .4V pk-pk signals.

Video Output

Two outputs of RS-170A or CCIR video with scene overlay of unique symbology and text. A third output has buffered input video.

Video Digitization

The input video is digitized to 8-Bits per pixel resolution at 10 MHz rate giving 512 pixel x 240 line resolution per RS-170 video field.

INTERFACE CAPABILITIES

Serial I/O

An 85C30 provides two serial ports which may be configured to RS485, RS422, RS232, RS423 standards and operate in a synchronous or asynchronous mode at 1 M Bit/sec max.

Parallel I/O

An 82C55A Programmable Peripheral Interface (PPI) can be configured for mode 1 operation to provide a high speed parallel interface to a host computer or the 82C55A can provide 24 digital I/O lines.

Analog I/O

Four 12-Bit A/D Channels with an input range of $\pm 10V$ FS & Four 12-Bit D/A Channels with an output range of $\pm 10V$ FS

VMEbus Interface

All SDD-5000 modules comply with VMEbus specification ANSI/IEE STD 1014-1987 and are configured as A:16, D:16 DTB Slave modules. The form factor is 6U x160mm.

PERFORMANCE CHARACTERISTICS

Tracking Algorithm

The SDD-5000 supports centroid and correlation tracking algorithms. The mathematical resolution of the error signal is 1/64 of a pixel. The error signal is updated at a rate of 60 Hz.

Target Segmentation

A target segmentation algorithm is provided that supports bright, dark, or multi-modal targets. When multi-mode segmentation is selected, the target is segmented from the background using histogramming techniques and statistical methods. Target segmentation signal-to-noise ratio is 2:1.

For more information, please contact:

Gary West
Director
205-581-2267
west@sri.org

John Collier
Program Manager
205.581.2508
collier@sri.org

Tracking Gate Size

The tracking gate size is automatically adjusted from 2% to 50% of the field-of-view (FOV) to adapt to a target that is less than 1% of the FOV.

Tracking Gate Position

In SCAN mode, the track gate can be manually positioned anywhere within the FOV. In TRACK mode, the track gate automatically follows the target anywhere within the FOV.

Intelligent Coast Mode

The SDD-5000 evaluates target parameters each video field. If the target becomes obscured, the coast mode will track the predicted target path based on stored target data.

Tracking Offset

The azimuth and elevation null point can be located within $\pm 50\%$ from the center of the FOV.

Display Symbology

The SDD-5000 has capabilities of graphic overlay on both channels. The graphics include various crosshairs and alphanumeric characters. The display scan be customized to the customer's specifications.

Diagnostics

The SDD-5000 performs power-on BIT tests that provide fault isolation reporting to the sub-module level. Additional diagnostics are available with a software monitor which can be accessed via a RS232 diagnostic port.

POWER

24-30 VDC at 4.5 Amperes, or 120VAC $\pm 10\%$, 50-60Hz at 2 Amperes.

TEMPERATURE RANGE

- Operating
 - Commercial:* 0°C to 55°C
 - Ruggedized:* -30°C to 70°C
 - Military:* -55°C to 85°C
- Non-Operating
 - Commercial:* -50°C to 100°C
 - Military:* -62° C to 125°C

OPTIONS

- Custom software for special tracking algorithms, special gate formats, custom video output symbology
- Servo Platform Interface with Analog I/O
- Remote Control Panel
- System Integration
- Ruggedized Hardware
- Mil-SPEC Hardware
- Custom Packaging

SOUTHERN RESEARCH

Legendary Discoveries. Leading Innovation.

Birmingham Alabama | 800.967.6774 | www.SouthernResearch.org